



MANUAL OF ADMINISTRATION

TOPIC: HEALTH AND SAFETY	SUBJECT: Musculoskeletal Disorders Prevention (MSD) – Wheelchair Safety	Code: HS124
		Date of Issue: February 2008
		Revised: November 2019
		Page 1 of 4

POLICY STATEMENT:

It is the purpose of this policy to eliminate MSD injuries while supporting someone in a wheelchair.

PROCEDURES/RESPONSIBILITIES

Employee:

1. Maintenance

Each time, prior to supporting someone in a wheelchair an inspection must first be carried out by the employee, to ensure the wheelchair is in proper working order. (See Figure 1)

- Brakes are in good repair and are easily placed in position. The chair does not move when the brakes are locked.
- Wheels/tires have the correct amount of air and have proper treads.
- Hand rims are free of surface damages.
- Upholstery is clean and free of odors and tears.
- Handgrips are in place and fitted properly.
- Footrests are secure and in good working order.
- Support Straps are all secure prior to moving.
- Seat belt is in place and in good repair.
- Anti-tip guards are secure and in the correct position.
- Electric wheelchairs are fully charged. If the chair breaks down while you are supporting, call the person's home for direction. **Never push an electric wheelchair, unless it can be switched to manual and rolls easily.**
- **Never lift an electric wheelchair.**
- Inform the individual's family or main contact of any concerns regarding the condition of the wheelchair, or damages, as soon as possible. Document the concerns on an incident report; contact On Call/Manager for immediate concerns.

MANUAL OF ADMINISTRATION

TOPIC: HEALTH AND SAFETY	SUBJECT: Musculoskeletal Disorders Prevention (MSD) – Wheelchair Safety	Code: HS124
		Date of Issue: February 2008
		Revised: November 2019
		Page 2 of 4

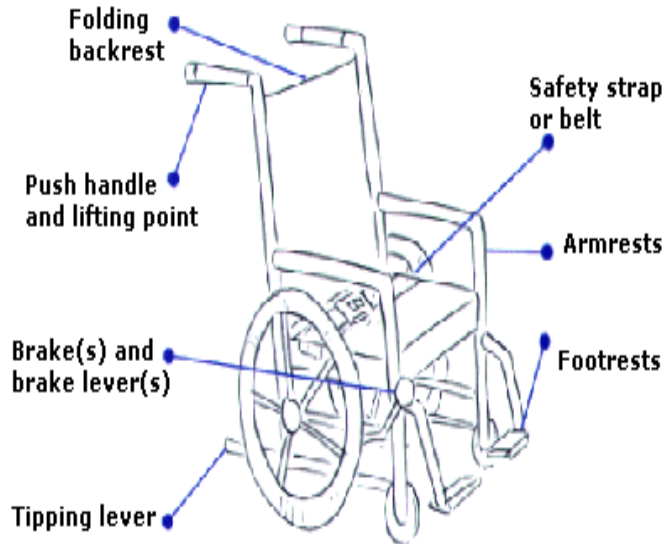

Figure 1

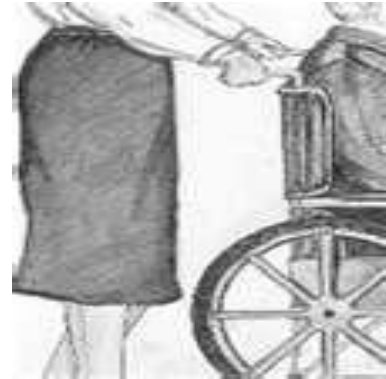

Figure 2

2. Proper Pushing on Flat Surfaces

- Always inform the person of your intentions.
- Plan for the safest route to your destination where sloped curbs, ramps and flat surfaces are available.
- Avoid pushing a wheelchair when conditions such as rain, snow or long grass cause pushing to become strenuous.
- Use both hands when pushing a wheelchair.
- Ensure bags on the back rest do not interfere with your proper body posture or the correct balance of the chair.
- Try to maintain a 90 degree angle for your wrists, arms and shoulders when pushing. If you're unable to push the wheelchair safely, inform your supervisor immediately. (see Figure 2)
- Do not rush, use a sensible speed.
- Before starting to push ensure the person's feet are properly positioned on the foot rest, the seat belt is secure and the wheels are free of objects that may get stuck during the walk.
- Use ramps or sloped sidewalks at all times.
- Anti-tip bars shall remain in place at all times.
- If stopping for any period of time brakes must be put in the locked position.
- Watch for small lips or changes in flooring that may cause difficulties for pushing.

TOPIC: HEALTH AND SAFETY	SUBJECT: Musculoskeletal Disorders Prevention (MSD) – Wheelchair Safety	Code: HS124
		Date of Issue: February 2008
		Revised: November 2019
		Page 3 of 4

3. Proper Ramp Use

- Never lift the wheelchair off the ground – See proper use to access raised surfaces.
- Inform the person when going up and down the ramp.
- Ensure the seat belt is safely secured.
- Go up the ramp frontwards. Never pull a wheelchair up a ramp.
- If the ramp is steep go down backwards.

4. Proper Use to Access Raised Surfaces (no higher than 3 inches)

- **Never lift a manual or electric wheelchair up a raised surface.**
- Inform the person of your intentions.
- Ensure the persons feet are safely on the footrests.
- Use the tip bar or anti-tip guard to tip the chair up only as high as necessary.
- Place the front wheels on the raised surface.
- Push steadily and firmly until the large wheels ride up.
- Ensure the wheelchair is safely on the raised surface.
- It is best to use a sloped curb or ramp.

5. Pushing a wheelchair downhill

- Plan for the safest route to your destination to avoid steep slopes if possible.
- When the hill is very steep it is advisable to go down backwards to prevent the person on the wheelchair from tilting forward.
- Remember a slope going out is a hill coming back.

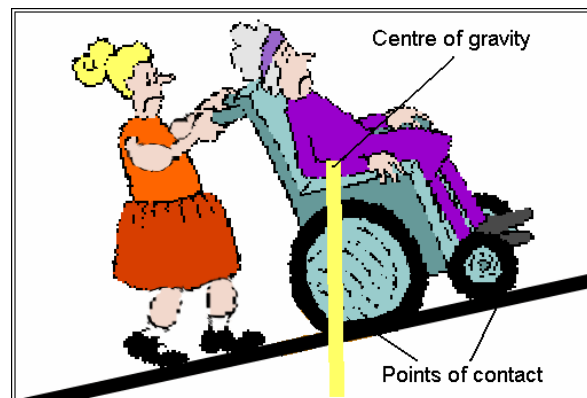

MANUAL OF ADMINISTRATION

TOPIC: HEALTH AND SAFETY	SUBJECT: Musculoskeletal Disorders Prevention (MSD) – Wheelchair Safety	Code: HS124
		Date of Issue: February 2008
		Revised: November 2019
		Page 4 of 4

6. Transporting a wheelchair in a vehicle

- Only transport wheelchair in a vehicle at the direction of a Manager.
- Alternate means of transportation should be utilized first (Lift+, City Transit, Taxi)
- Remove any cushions or backrests.
- Remove footplates and armrests.
- Fold wheelchair and engage brakes.
- Bend your knees, keep your back straight and lean the wheelchair frame towards you.
- Grasp both sides of the wheelchair frame and roll the chair up onto your thighs.
- Straighten your legs to lift the chair up and into the trunk.
- Remember to use your leg muscles not your back.

If a wheelchair must be stored in a home please ensure it is easily accessible and stored safely.

Supervisor:

1. Ensure staff receives proper training in wheelchair safety.
2. Address concerns with an individual's family or main contact regarding the condition of a wheelchair, if employee concerns are not followed up within a reasonable period of time.
3. Investigate causes of MSD when reported.